

1.1.12 HOLLOW PIN CHAIN

• Shining HP chains include heat treated sidebars for 'double Strength' and case carbonized pins, bushes and rollers for optimum abrasion resistance. HP series denotes hollow bearing pin to allow cross rods or bolts to be fitted through the chain strands.

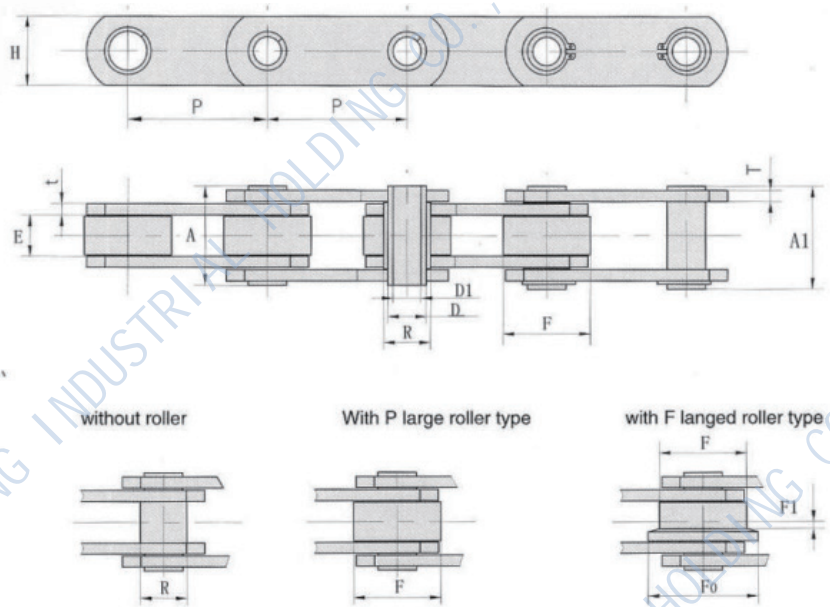

Chain No.	Average Pitch							E(mm) min	Sidebar		Pin	
									t/T (mm) max	H(mm) max	D (mm) max	D1(mm) max
	P											
ZC21	38.1	50.8	63.5	76.2	-	-	-	12.7	2.5	18.0	9.0	6.5
ZC40	50.8	63.5	76.2	88.9	101.6	127.0	152.4	15.0	4.0	25.0	14.0	10.2
ZC60	76.2	88.9	101.6	127.0	152.4	177.8	203.2	19.0	5.0/4.0	40.0	19.0	13.2
ZC150	101.6	127.0	152.4	177.8	203.2	228.6	254.0	26.0	7.0/5.0	50.0	26.9	20.2
ZC300	152.4	177.8	203.2	254.0	304.8	-	-	38.0	10.0/8.0	60.0	32.0	22.5

Chain No.	Pin		Barrel		F0 (mm) Max	Roller	Min.Ult.Strength	
	A (mm) max	A1 (mm) max	R(mm) max	F (mm) Max			Q(KN)	*Q(KN)
ZC21	26.0	27.5	11.0	25.4	-	-	21.0	-
ZC40	36.4	37.7	17.0	31.8	40.0	2.5	40.0	50.0
ZC60	45.0	46.0	23.0	47.5	60.0	3.5	60.0	120.0
ZC150	58.0	60.5	33.0	66.7	82.0	4.0	150.0	190.0
ZC300	83.0	85.0	38.0	88.9	114.0	8.5	300.0	380.0

1.1.12 HOLLOW PIN CHAIN

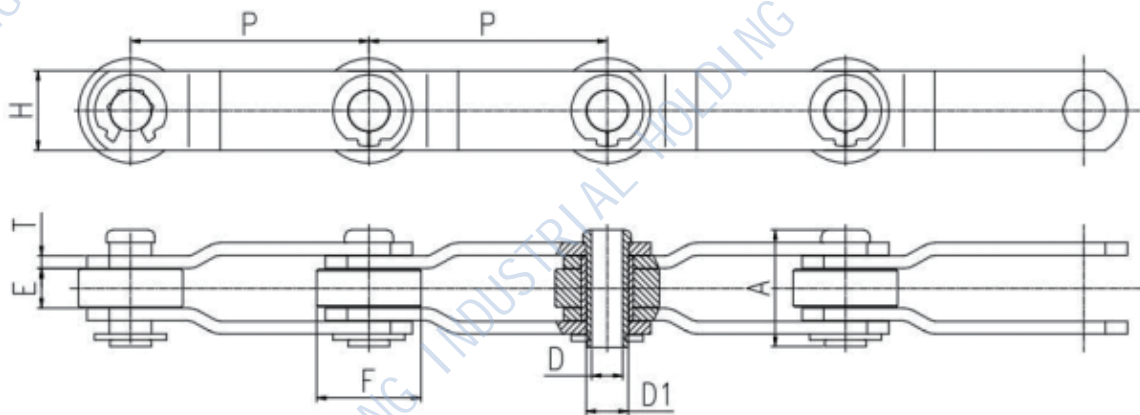

Chain No.	Pitch	Pin		F (mm) Max	E (mm)	T (mm)	H (mm)	A (mm)
		D (mm)	D1 (mm)					
SB6P40HP	152.4	20	26.9	66.7	25.4	8	50.8	75.1

1.1.12 HOLLOW PIN CHAIN

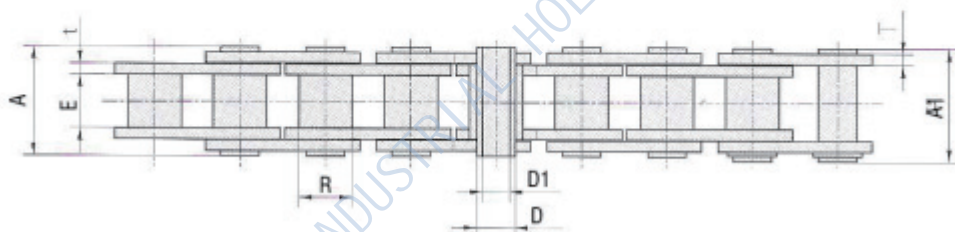
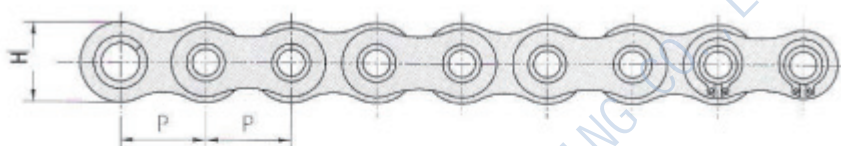

Chain No.	Pitch P	E(mm) min	Sidebar		Pin				Barrel R(mm) max	Min.Ult Strength Q(KN)	Avg.Ult. Strength Qo(KN)	Avg. Chain Weight kg/FT
			T(mm) max	H(mm) max	D(mm) max	D1(mm) max	A(mm) max	A1(mm) max				
08BHPF	12.700	7.75	1.6/1.3	11.80	6.55	4.50	16.40	17.60	8.51	11.10	12.10	0.171
08BHPPF5	12.700	7.75	1.60	12.00	6.30	4.50	16.80	18.00	8.51	9.60	10.60	0.189
10BHPPF3	15.875	9.65	1.70	14.70	7.02	5.13	19.50	20.50	10.16	10.00	11.50	0.262
10BHPPF4	15.875	9.50	2.03/1.6	14.00	7.20	5.00	19.80	21.30	10.16	12.50	14.00	0.25
12BHPPF2	19.050	11.68	1.85	16.10	8.09	6.00	22.70	23.90	12.07	14.00	16.00	0.25
12BHPPF3	19.050	11.70	2.42/1.85	16.20	8.22	5.75	23.60	24.90	12.07	16.00	18.00	0.347
40HP	12.700	7.85	1.50	12.00	5.63	4.00	16.50	17.60	7.95	11.00	12.20	0.165
50HP	15.875	9.40	2.03	15.09	7.03	5.13	20.70	21.90	10.16	20.00	22.60	0.277
60HP	19.050	12.70	2.42	18.00	8.31	6.00	25.80	26.80	11.91	24.00	26.90	0.393
60HPF1	19.050	12.70	2.42	18.00	7.31	5.01	25.50	26.80	11.91	28.00	30.90	0.418
80HP	25.400	15.75	3.25	24.00	11.40	8.05	32.50	33.80	15.88	50.00	52.00	0.689
80HPF2	25.400	15.75	3.25	24.00	11.40	8.40	32.50	33.80	15.88	45.00	48.00	0.68

1.1.12 HOLLOW PIN CHAIN

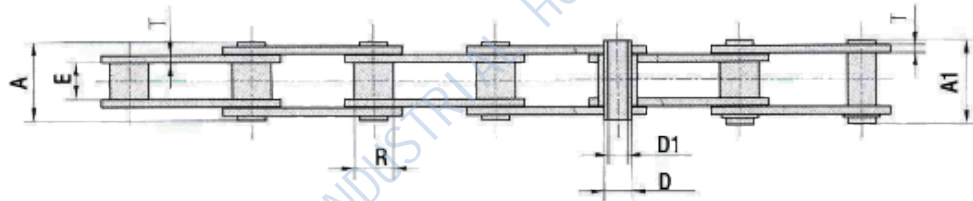
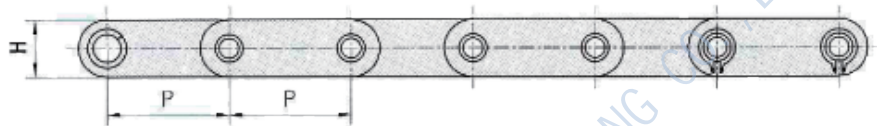

Chain No.	Pitch P	E(mm) min	Sidebar		Pin				Barrel R(mm) max	Min.Ult Strength Q(KN)	Avg.Ult. Strength Qo(KN)	Avg. Chain Weight kg/FT
			T(mm) max	H(mm) max	D(mm) max	D1(mm) max	A(mm) max	A1(mm) max				
C2040HP	25.400	7.85	1.50	12.00	5.63	4.00	16.50	17.60	7.95	11.00	12.60	0.14
C2050HP	31.750	9.40	2.03	15.00	7.22	5.12	20.50	21.80	10.16	20.40	22.80	0.232
C2060HP	38.100	12.70	2.42	17.00	8.31	6.00	25.80	26.80	11.91	24.00	27.10	0.311
HP40F1	40.000	22.00	5.00	35.00	12.00	8.00	47.50	48.20	18.00	57.00	63.80	1.64
HP40F2	40.000	22.00	5.00	35.00	12.00	8.20	47.50	48.20	18.00	57.00	63.00	1.637
C2080HP	50.800	15.75	3.25	24.00	11.40	8.05	32.50	33.80	15.88	50.00	52.00	0.552
HP50F1	50.000	14.50	3.10	40.00	20.00	14.70	35.30	36.20	26.00	30.00	33.60	1.213
C40HP	12.700	7.85	1.50	12.00	5.63	4.00	16.50	17.60	7.95	11.00	12.20	0.195
C50HP	15.875	9.40	2.03	15.09	7.03	5.13	20.70	21.90	10.16	20.00	22.60	0.32
C60HP	19.050	12.70	2.42	18.00	8.31	6.00	25.80	26.80	11.91	24.00	26.90	0.463
C80HP	25.400	15.75	3.25	24.00	11.40	8.05	32.50	33.80	15.88	50.00	52.00	0.802